

# Galanz

## USER GUIDE

1.7Cu.Ft. Oven-the-Range Microwave

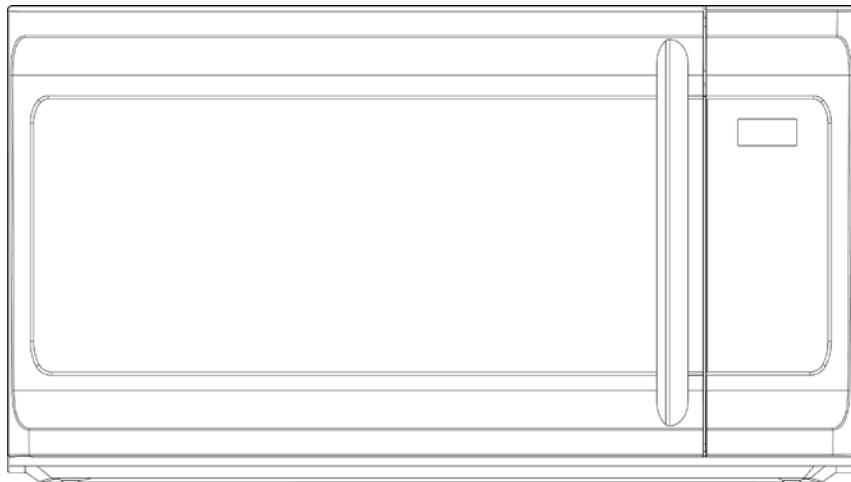

P100D48AL-JC  
GLOMJC17WE-10

Please read these instructions carefully before installing and operating the oven.

# CONTENTS

IMPORTANT SAFETY INSTRUCTIONS.....	2
PRECAUTIONS TO AVOID POSSIBLE EXPOSURE TO EXCESSIVE MICROWAVE ENERGY .....	4
UNPACKING INSTRUCTIONS.....	4
GROUNDING INSTRUCTIONS .....	5
INFORMATION YOU NEED TO KNOW .....	6
SPECIFICATIONS .....	10
FEATURES DIAGRAM .....	11
CONTROL PANEL FEATURES.....	12
BASIC CONTROLS.....	14
Function description: .....	14
Setting the Clock .....	14
Setting Microwave cooking program.....	14
Multi stage cooking.....	15
Light Control.....	15
Vent Fan Control .....	15
SPECIAL FEATURES .....	16
Auto cook menu.....	16
Kids Meals .....	17
Weight Defrost.....	18
1Lb Defrost.....	18
Time Defrost.....	18
OTHER CONVENIENT FEATURES .....	19
Add 30Sec.....	19
Setting the Time .....	19
Eco Mode .....	19
Child Lock .....	19
CLEAR AND CARE.....	20

# IMPORTANT SAFETY INSTRUCTIONS

When using electrical appliances, basic safety precautions should be followed, including the following:

**WARNING** - To reduce the risk of burns, electric shock, fire, and injury to persons or exposure to excessive microwave energy:

- Read all instructions before using the appliance.
- Read and follow the specific "PRECAUTIONS TO AVOID POSSIBLE EXPOSURE TO EXCESSIVE MICROWAVE ENERGY" on page 4.
- This appliance must be grounded. Connect only to properly grounded outlet. See "GROUNDING INSTRUCTIONS" on page 5.
- Install or locate this appliance only in accordance with the provided installation instructions.
- Some products such as whole eggs and sealed containers -for example, closed glass jars- are able to explode and should not be heated in this oven.
- Use this appliance only for its intended use as described in this manual. Do not use corrosive chemicals or vapors in this appliance. This type of oven is specifically designed to heat, cook, or dry food. It is not designed for industrial or laboratory use.
- As with any appliance, close supervision is necessary when used by children.
- To reduce the risk of fire in the oven cavity:
  - Do not overcook food. Carefully attend appliance when paper, plastic, or other combustible materials are placed inside the oven to facilitate cooking.
  - Remove wire twist-ties from paper or plastic bags before placing bag in oven.
  - If materials inside the oven should ignite, keep oven door closed, turn oven off, and disconnect the power cord or shut off power at the fuse or circuit breaker panel.
  - Do not use the cavity for storage purposes. Do not leave paper products, cooking utensils or food in the cavity when not in use.
- Liquids, such as water, coffee, or tea can be overheated beyond the boiling point without appearing to be boiling due to surface tension of the liquid. Visible bubbling or boiling when the container is removed from the microwave oven is not always present. **THEY COULD RESULT IN VERY HOT LIQUIDS SUDDENLY BOILING OVER WHEN A SPOON OR OTHER UTENSIL IS INSERTED INTO THE LIQUID.** To reduce the risk of injury to person:
  - Do not overheat the liquid.
  - Stir the liquid both before and halfway through heating it.
  - Do not use straight-sided containers with narrow necks.
  - After heating, allow the container to stand in the microwave oven for a short time before removing the container.
  - Use extreme care when inserting a spoon or other utensil into the container.
- Do not heat oil or fat for deep-frying. It is difficult to control the temperature of oil in microwave oven.
- Pierce foods with heavy skins such as potatoes, whole squash, apples and chestnuts before cooking.
- The contents of feeding bottles and baby jars should be stirred or shaken and the temperature should be checked before serving in order to avoid burns.
- Cooking utensils may become hot because of heat transferred from the heated food. Potholders may be needed to handle the utensil.

- Do not cover or block any openings on the appliance.
- Do not store or use this appliance outdoors. Do not use this product near water, for example, near a kitchen sink, in a wet basement, near a swimming pool, or similar locations.
- Do not operate this appliance if it has a damaged cord or a plug, if it is not working properly or if it has been damaged or dropped.
- Do not immerse cord or plug in water. Keep cord away from heated surface. Do not let cord hang over edge of table or counter.
- Use only thermometers, which are specifically designed for use in microwave ovens.
- Do not operate any heating or cooking appliance beneath this appliance.
- Be certain the glass tray and roller rings are in place when you operate the oven
- This appliance should be serviced only by qualified service personnel, contact nearest authorized service facility for examination, repair, or adjustment.
- When cleaning surfaces of door and oven that comes together on closing the door, use only mild, nonabrasive soaps, or detergents applied with a sponge or soft cloth.
- VENTILATING HOODS
  - Clean Ventilating Hoods Frequently-Grease should not be allowed to accumulate on hood or filter.
  - When flaming foods under the hood, turn the fan on.
- Use care when cleaning the vent-hood filter. Corrosive cleaning agents, such as lye-based oven cleaners, may damage the filter.
- Use care when cleaning the vent-hood filter. Corrosive cleaning agents, such as lye-based oven cleaners, may damage the filter.
- Suitable for use above both gas and electric cooking equipment.
- This equipment generates, uses and can radiate radio frequency energy and, if not installed and used in accordance with the instructions, may cause harmful interference to radio communications. However, there is no guarantee that interference will not occur in a particular installation. If this equipment does cause harmful interference to radio or television reception, which can be determined by turning the equipment off and on, the user is encouraged to try to correct the interference by one or more of the following measures:
  - Reorient or relocate the receiving antenna.
  - Increase the separation between the equipment and receiver.
  - Connect the equipment into an outlet on a circuit different from that to which the receiver is connected.
  - Consult the dealer or an experienced radio/TV technician for help.

**SAVE THESE INSTRUCTIONS**

## PRECAUTIONS TO AVOID POSSIBLE EXPOSURE TO EXCESSIVE MICROWAVE ENERGY

- (a) Do not attempt to operate this oven with the door open since open-door operation can result in harmful exposure to microwave energy. It is important not to defeat or tamper with the safety interlocks.
- (b) Do not place any object between the oven front face and the door or allow soil or cleaner residue to accumulate on sealing surfaces.
- (c) Do not operate the oven if it is damaged. It is particularly important that the oven door close properly and that there is no damage to the:
  - ① Door (bent),
  - ② Hinges and latches (broken or loosened),
  - ③ Door seals and sealing surfaces.
- (d) The oven should not be adjusted or repaired by anyone except properly qualified service personnel.

## UNPACKING INSTRUCTIONS

### Unpacking and Examining Your Oven

Carefully remove oven from carton. **SAVE THE CARTON AS IT MAY MAKE INSTALLATION EASIER.**

Remove:

1. All packing materials from inside the oven cavity; however, **DO NOT REMOVE THE WAVEGUIDE COVER**, which is located on the ceiling in the oven cavity. Check to see that there are Installation Instructions, Wall Template, Top Cabinet Template, bag of Installation Hardware, Charcoal Filter and Exhaust Damper Assembly. Read enclosures and **SAVE** the Owner's Instructions.
2. The feature sticker from the outside of the door, if there is one.

Check the oven for any damage, such as misaligned or bent door, damaged door seals and sealing surfaces, broken or loose door hinges and latches and dents inside the cavity or on the door. If there is any damage, do not operate the oven and contact your dealer.

See Installation Instruction for more details.

# GROUNDING INSTRUCTIONS

This appliance must be grounded. In the event of an electrical short circuit, grounding reduces the risk of electric shock by providing an escape wire for the electric current. This appliance is equipped with a cord having a grounding wire with a grounding plug. The plug must be plugged into an outlet that is properly installed and grounded.

**WARNING-** Improper use of the grounding plug can result in a risk of electric shock.

Consult a qualified electrician or serviceman if the grounding instructions are not completely understood or if doubt exists as to whether the appliance is properly grounded. If it is necessary to use an extension cord, use only a 3-wire extension cord that has a 3-blade grounding plug, and a 3-slot receptacle that will accept the plug on the appliance. The marked rating of the extension cord shall be equal to or greater than the electrical rating of the appliance.

## Electrical Requirements

The electrical requirements are a 120 volt 60 Hz, AC only, 20 amp. It is recommended that a separate circuit serving only the oven be provided. The oven is equipped with a 3-prong grounding plug. It must be plugged into a wall receptacle that is properly installed and grounded.

### Power Supply Cord

1. A short power supply cord is provided to reduce the risks resulting from becoming entangled in or tripping over a longer cord.
2. Longer cord sets or extension cords are available and may be used if care is exercised in their use.
3. If long cord or extension cord is used:
  - a) The marked electrical rating of the cord set or extension cord should be at least as great as the electrical rating of the appliance.
  - b) The extension cord must be a grounding-type 3-wire cord, and The longer cord should be arranged so that it will not drape over the counter top or table top where it can be pulled on by children or tripped over unintentionally.

### NOTES:

1. If you have any questions about the grounding or electrical instructions, consult a qualified electrician or service person.
2. Neither Galanz nor the dealer can accept any liability for damage to the oven or personal injury resulting from failure to observe the electrical connection procedures.

## Radio or TV Interference

Should there be any interference caused by the microwave oven to your radio or TV, check that the microwave oven is on a different circuit, relocate the radio or TV as far away from the oven as feasible or check position and signal of receiving antenna.

# INFORMATION YOU NEED TO KNOW

## ABOUT YOUR OVEN

**NEVER** use the oven without the turntable and support nor turn the turntable over so that a large dish could be placed in the oven. The turntable will turn both clockwise and anticlockwise.

The shelf gives you the option to reheat more than one dish of food at the same time. To reheat on 2 levels:

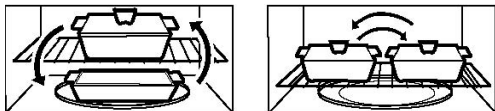

- Switch places after  $\frac{1}{2}$  the time.
- Make sure the shelf is positioned properly inside the microwave to prevent damage to the oven from arcing.
- Do not use a microwave browning dish on the shelf. The shelf could overheat.
- Do not use the oven with the shelf on the microwave floor. This could damage the microwave.
- Use pot holders when handling the shelf-it may be hot.
- Do not use the shelf when cooking popcorn.

**ALWAYS** have food in the oven when it is on to absorb the microwave energy.

When using the oven at power levels below 100%, you may hear the magnetron cycling on and off.

Condensation is a normal part of microwave cooking. Room humidity and the moisture in food will influence the amount of moisture that condenses in the oven. Generally, covered foods will not cause as much condensation as uncovered ones. Ventilation openings must not be blocked.

In using recipes or package directions, check food a minute or two before the minimum time and add time accordingly.

## ABOUT MICROWAVE COOKING

Arrange food carefully. Place thickest areas towards outside of dish.

- Watch cooking time. Cook for the shortest amount of time indicated and add more as needed. Food severely overcooked can smoke or ignite.
- Cover foods while cooking. Check recipe or cookbook for suggestions: paper towels, wax paper, microwave plastic wrap or a lid. Covers prevent splattering and help foods to cook evenly.
- Shield with small flat pieces of aluminum foil any thin areas of meat or poultry to prevent overcooking before dense, thick areas are cooked thoroughly.
- Stir foods from outside to center of dish once or twice during cooking, if possible.
- Turn foods over once during microwaving to speed cooking of such foods as chicken and hamburgers. Large items like roasts must be turned over at least once.
- Rearrange foods such as meatballs halfway through cooking both from top to bottom and from the center of the dish to the outside.
- Add standing time. Remove food from oven and stir, if possible. Cover for standing time that allows the food to finish cooking without overcooking.
- Check for doneness. Look for signs indicating that cooking temperatures have been reached.
- Doneness signs include:
  - Food steams throughout, not just at edge.

- Center bottom of dish is very hot to the touch.
- Poultry thigh joints move easily.
- Meat and poultry show no pinkness.
- Fish is opaque and flakes easily with a fork.

## ABOUT FOOD

FOOD	DO	DON'T
Eggs, sausages, fruits & vegetable	<ul style="list-style-type: none"> <li>• Puncture egg yolks before cooking to prevent "explosion".</li> <li>• Pierce skins of potatoes, apples, squash, hot dogs and sausages so that steam escapes.</li> </ul>	<ul style="list-style-type: none"> <li>• Cook egg in shells.</li> <li>• Reheat whole eggs.</li> </ul>
Popcorn	<ul style="list-style-type: none"> <li>• Use specially bagged popcorn for the microwave oven.</li> <li>• Listen while popping corn for the popping to slow to 1 or 2 seconds or use special Popcorn pad.</li> </ul>	<ul style="list-style-type: none"> <li>• Pop popcorn in regular brown bags or glass bowls.</li> <li>• Exceed maximum time on popcorn package.</li> </ul>
Baby food	<ul style="list-style-type: none"> <li>• Transfer baby food to small dish and heat carefully, stirring often. Check temperature before serving.</li> <li>• Put nipples on bottles after heating and shake thoroughly. "Wrist" test before feeding.</li> </ul>	<ul style="list-style-type: none"> <li>• Heat disposable bottles.</li> <li>• Heat bottles with nipples on.</li> <li>• Heat baby food in original jars.</li> </ul>
General	<ul style="list-style-type: none"> <li>• Cut baked goods with filling after heating to release steam and avoid burns.</li> <li>• Stir liquids briskly before and after heating to avoid "eruption".</li> <li>• Use deep bowl, when cooking liquids or cereals, to prevent boilovers.</li> </ul>	<ul style="list-style-type: none"> <li>• Heat or cook in closed glass jars or airtight containers.</li> <li>• Can in the microwave as harmful bacteria may not be destroyed.</li> <li>• Deep fat fry.</li> <li>• Dry wood, gourds, herbs or wet papers.</li> </ul>

## ABOUT MICROWAVE COOKING

- Arrange food carefully. Place thickest areas towards outside of dish.
- Watch cooking time. Cook for the shortest amount of time indicated and add more as needed. Food severely overcooked can smoke or ignite.
- Cover foods while cooking. Check recipe or cookbook for suggestions: paper towels, wax paper, microwave plastic wrap or a lid. Covers prevent spattering and help foods to cook evenly.
- Shield with small flat pieces of aluminum foil any thin areas of meat or poultry to prevent overcooking before dense, thick areas are cooked thoroughly.
- Stir foods from outside to center of dish once or twice during cooking, if possible.
- Turn foods over once during microwaving to speed cooking of such foods as chicken and hamburgers. Large items like roasts must be turned over at least once.



- Rearrange foods such as meatballs halfway through cooking both from top to bottom and from the center of the dish to the outside.
- Add standing time. Remove food from oven and stir, if possible. Cover for standing time that allows the food to finish cooking without overcooking.
- Check for doneness. Look for signs indicating that cooking temperatures have been reached.
- Doneness signs include:
  - Food steams throughout, not just at edge.
  - Center bottom of dish is very hot to the touch.
  - Poultry thigh joints move easily.
  - Meat and poultry show no pinkness.
  - Fish is opaque and flakes easily with a fork.

## ABOUT SAFETY

Check foods to see that they are cooked to the following recommended temperatures.

TEMP	FOOD
160°F	...for fresh pork, ground meat, boneless white poultry, fish, seafood, egg dishes and frozen prepared food.
165°F	...for leftover, ready-to-reheat refrigerated, and deli and carry-out "fresh" food.
170°F	...white meat of poultry.
180°F	...dark meat of poultry.

- To test for doneness, insert a meat thermometer in a thick or dense area away from fat of bone. **NEVER** leave the thermometer in the food during cooking, unless it is approved for microwave oven use.
- **ALWAYS** use potholders to prevent burns when handling utensils that are in contact with hot food. Enough heat from the food can transfer through utensils to cause skin burns.
- Avoid steam burns by directing steam away from the face and hands. Slowly lift the farthest edge of a dish's covering and carefully open popcorn and oven cooking bags away from the face.
- Stay near the oven while it's in use and check cooking progress frequently so that there is no chance of overcooking food.
- **NEVER** use the cavity for storing cookbooks or other items.
- Select, store and handle food carefully to preserve its high quality and minimize the spread of food borne bacteria.
- Keep waveguide cover clean. Food residue can cause arcing and/or fires.
- Use care when removing items from the oven so that utensil, your clothes or accessories do not touch the safety door latches.

## ABOUT UTENSILS AND COVERINGS

It is not necessary to buy all new cookware. Many pieces already in your kitchen can be used successfully in your new microwave oven. Make sure the utensil does not touch the interior walls during cooking.

**Use these utensils for safe microwave cooking and reheating**

- glass ceramic
- heat-resistant glass
- microwave-safe plastics
- paper plates
- microwave-safe pottery, stoneware and porcelain
- browning dish

**These items can be used for short time reheating of foods that have little fat or sugar in them:**

- wood, straw, wicker

## **DO NOT USE**

- metal pans and bake ware
- dishes with metallic trim
- non-heat-resistant glass
- non-microwave-safe plastic
- recycled paper bags
- food storage bags
- metal twist-ties

Should you wish to check if a dish is safe for microwaving, place the empty dish in the oven and microwave on HIGH for 30 seconds. A dish which becomes very hot should not be used.

**The following coverings are ideal:**

- Paper towels are good for covering foods for reheating and absorbing fat while cooking bacon.
- Wax paper can be used for cooking and reheating.
- Plastic wrap that is specially marked for microwave use can be used for cooking and reheating. DO NOT allow plastic wrap to touch food. Vent so steam can escape.
- Lids that are microwave-safe are a good choice because heat is kept near the food to hasten cooking.
- Oven cooking bags are good for large meats or foods that need tenderizing. DO NOT use metal twist ties. Remember to slit bag so steam can escape.

**How to use aluminum foil in your microwave oven:**

- Small flat pieces of aluminum foil placed smoothly on the food can be used to shield areas that are either defrosting or cooking too quickly.
- Foil should not come closer than one inch to any surface of the oven.

**ACCESSORIES** There are many microwave accessories available for purchase. Evaluate carefully before you purchase so that they meet your needs. A microwave-safe thermometer will assist you in determining correct doneness and assure you that foods have been cooked to safe temperatures. Galanz is not responsible for any damage to the oven when accessories are used

## **ABOUT CHILDREN AND THE MICROWAVE**

- Children below the age of 7 should use the microwave oven with a supervising person very near to them. Between the ages of 7 and 12, the supervising person should be in the same room.
- The children must be able to reach the oven comfortably; if not, he/she should stand on a sturdy stool.
- At no time should anyone be allowed to lean or swing on the oven door.
- Children should be taught all safety precautions; use potholders, remove coverings carefully and

pay special attention to packages that crisp food because they may be extra hot.

- Don't assume that because a child has mastered one cooking skill he/she can cook everything.
- Children need to learn that the microwave oven is not a toy.

## SPECIFICATIONS

Power Supply		120V 20AC 60Hz Single phase
Microwave	Power Consumption	1650W
	Output Power	1000W
	Frequency	2450MHz
Outside Dimensions		$16 \frac{7}{8}$ "(H) $\times$ $29 \frac{7}{8}$ "(W) $\times$ $17 \frac{11}{16}$ "(D)
Cavity Dimensions		$10 \frac{3}{16}$ "(H) $\times$ $21 \frac{5}{16}$ "(W) $\times$ $14 \frac{10}{16}$ "(D)
Oven Capacity		1.7 Cu.Ft.
Cooking Uniformity		Turntable /Stirrer Fan System
Weight		Approx. (net) 53.6lb

# FEATURES DIAGRAM

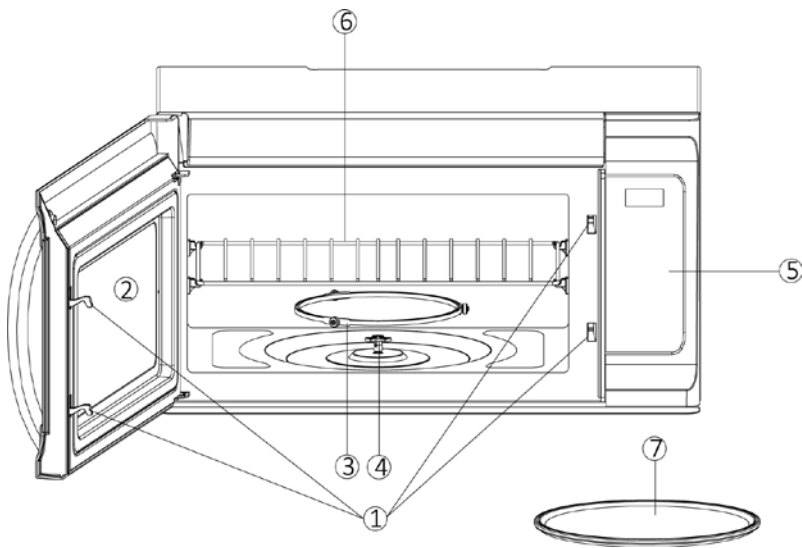

1. Door Safety Lock System
2. Oven Window
3. Roller Ring
4. Shaft
5. Control Panel
6. Shelf
7. Glass Tray

# CONTROL PANEL FEATURES

Your microwave oven control panel lets you select the desired cooking function quickly and easily. All you have to do is touch the necessary Command pad. The following is a list of all the Command and Number pads located on the control panel. For more information on these features, see the operation section.

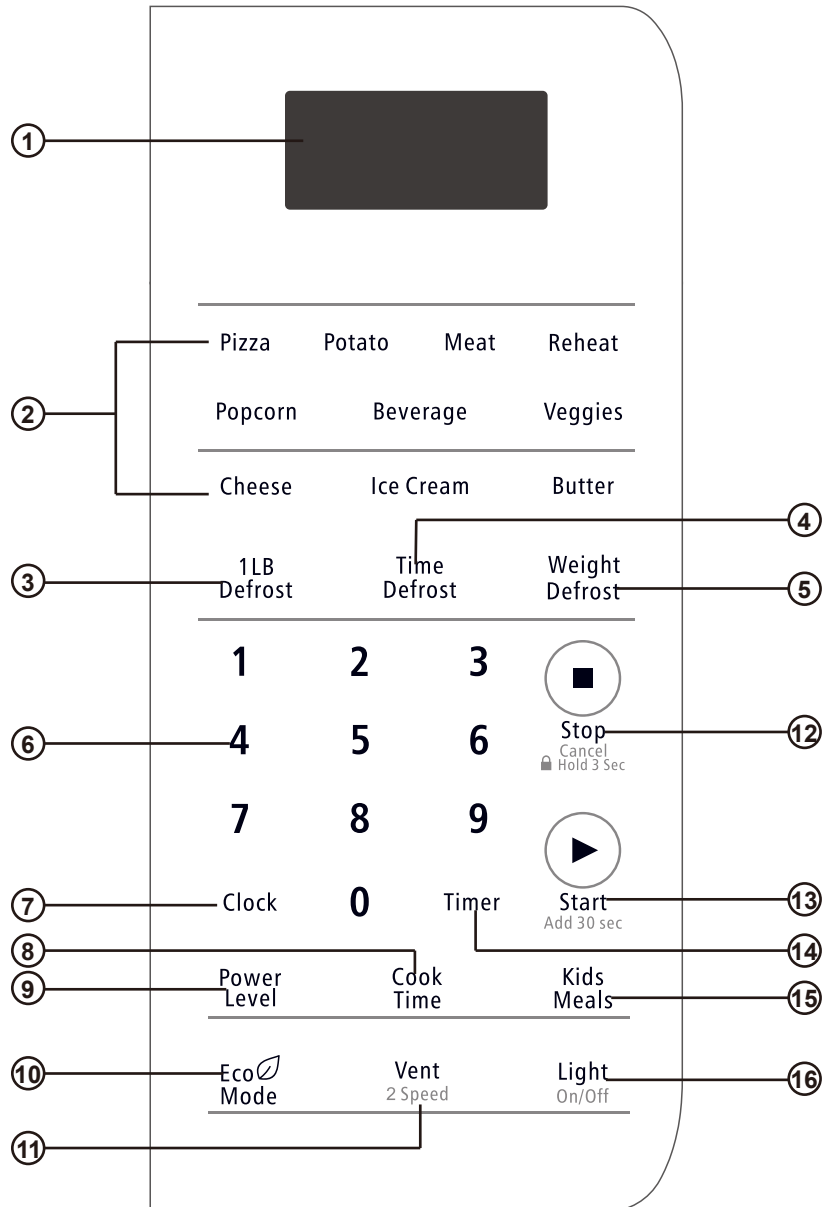

- 1. Display.** The display includes a clock and indicators to tell you time of day, cooking time settings and cooking functions selected.
- 2. Auto Cook Menu.** Use for instant settings of popular daily use. (Such as Pizza, Potato, Meat,

Reheat, Popcorn, Beverage, Veggies, Cheese, Ice Cream, Butter).

3. **1 LB Defrost.** Touch this button to defrost frozen food quickly.
4. **Time Defrost.** Use to defrost food based on time enter.
5. **Weight Defrost.** Use to defrost food based on weight enter.
6. **Number.** Touch number pads to enter cooking time, power level or food weight.
7. **Clock.** Touch the pad to enter the time of day.
8. **Time Cook.** Touch this pad to set cooking time.
9. **Power Level.** Touch this pad to set cooking power level.
10. **Eco Mode.** Touch this pad to set power save mode.
11. **Vent 2 Speed.** Touch this pad to change vent speed.
12. **Stop/Cancel.** Touch this pad to stop the oven or press this pad for 3 seconds to set child lock.
13. **Start/Add 30 Sec.** Touch to start the oven; also use to start the oven quickly at full power or use to add cooking time.
14. **Timer.** Touch this pad to set kitchen timer.
15. **Kids Meals.** Select type of dish to reheat Chicken nuggets, Hot dogs, Fresh fries, Frozen sandwiches.
16. **Light On/Off.** Touch this pad to turn the light on high/low or off.

# BASIC CONTROLS

## Learn about your microwave oven.

### CAUTION

- To avoid risk of personal injury or property damage, do not operation the microwave oven empty.
- To avoid risk of personal injury or property damage, do not use stoneware, aluminum foil, metal utensils, or mental trimmed utensils in the microwave oven.

### Function description:

- When the oven first plugged in, the display will show “12:00” and “:” flashing.
- When cooking setting is interrupted for 1 minute, the system will back to the standby mode automatically.
- During cooking, if press **Stop/Cancel** pad once or open the door, the program will be paused, close the door, then press **Start/Add 30Sec** pad to resume, but if press **Stop/Cancel** pad twice, the program will be canceled.
- After ending cooking, “END” will display and the system will sound beeps to remind user every two minutes until user press **Stop/Cancel** pad or open the door.
- SIGNALS DURING OVEN SETTINGS  
**ONE SIGNAL:** Oven accepts the entry.  
**TWO SIGNALS:** Oven does not accept the entry, please check and try again.

## Setting the Clock

This is a 12 or 24 hour clock. In standby mode, touch **Clock** pad once to choose 12 hour clock and if you want to choose 24 hour clock, press the pad again

Example: Suppose you want to set the clock for 8:08 am.

1. In standby mode, touch **Clock** pad once or twice.
2. Press number pads **8, 0, 8**, the display will show “08:08”.
3. Touch **Start/Add 30Sec** to confirm

### NOTE:

- During cooking, you can press **Clock** pad to check the clock.
- “00:00” will display and two beeps will sound to remind user to resume load the time, if you enter time is beyond the scope of clock when you set the clock.

## Setting Microwave cooking program

For microwave cooking, cooking power and time should be set. The longest cooking time you can set is 99 minutes, 99 seconds. Press **Power Level** pad once and then press number pads to choose cooking power level.

Use number pad choose cooking power level			
Press Number pad	Power level(Display)	Press Number pad	Power level(Display)
1、 0	100%(PL10)	4	40%(PL-4)
9	90%(PL-9)	3	30%(PL-3)
8	80%(PL-8)	2	20%(PL-2)
7	70%(PL-7)	1	10%(PL-1)
6	60%(PL-6)	0	0%(PL-0)
5	50%(PL-5)		

For example, suppose you want to cook at 80% power level for 10 minutes.

1. In standby mode, press **Time Cook** pad once.
2. Use the number pads to enter cooking time.
3. Touch **Power Level** pad once, and then use the number pad “8” to select 80% power level.
4. Touch **Start/Add 30Sec** pad to confirm.

**NOTE:** During cooking you can press **Power level** to check the power level, and you can adjust the power level by pressing number pads when the display shows the power level.

## Multi stage cooking

For best results, some recipes call for different cook power during different stages of a cook cycle. You can program your oven to switch from one power to another for up to 2 stages.

For example, suppose you want to set the following cooking program.

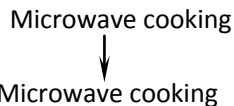

1. In waiting mode, input the first Microwave cooking. Do not touch **Start/Add 30Sec** pad
2. Press **Time Cook** pad once, and then input the second Microwave cooking.
3. Touch **Start/Add 30Sec** to start.

**NOTE:** Auto menu, defrost and Kids meals cannot set in multi stage cooking program.

## Light Control

This feature is designed for the convenience of doing things outside the oven. To turn on the light at the bottom of the oven, press **Light On/Off** pad:

Press <b>Light On/Off</b> button	Working Mode
Once	On
Twice	Off

## Vent Fan Control

Your oven can be used as a range hood. When it is turned on, the fan motor starts filtering out smoke, odors, and grease generated from cooking.



In standby mode, the vent fan is manual control, continuous press **Vent/2 Speed** can choose three cycle gears:

Press <b>Vent/2 Speed</b> button	Working Mode	Display
Once	Low wind	Vent .L
Twice	High Wind	Vent .H
3 times	Turn off	Put Out

**NOTE:** When cooking is started, the suction fan automatically works into a low wind gear, and “Vent.L” will display. During cooking in a session, you can choose low wind or high wing gear.

## SPECIAL FEATURES

### Auto cook menu

For foods such as Butter, Cheese and Ice cream, it is not necessary to program the time and the cooking power. It is sufficient to indicate the type of food that you want to cook as well as the weight of this food.

#### ➔ Butter, Cheese or Ice cream

1. Press the food (**Butter, Cheese and Ice cream**) pad once.
2. Use number pad “**1**,” “**2**” to select the amount (according to the amount in the table below).
3. Touch **Start/Add 30Sec** pad to confirm.

Food	Amount	Press number pad	Total time
Butter	1(4oz)	1	1:00
	2( 8oz)	2	1:30
Cheese	1(4oz)	1	1:00
	2(8oz)	2	1:30
Ice cream	1	1	0:30
	2	2	0:45

#### ➔ Pizza, Potato, Meat, Reheat and Veggies

1. Press the food pad desired (**Pizza, Potato, Meat, Reheat or Veggies**).
2. Use number pad (0 - 9) to enter food weight.
3. Touch **Start/Add 30Sec** pad to start cooking.

Food	Weight ranges	Power level
Pizza	10oz~28oz	PL10
Potato	1oz~48oz	PL10
Meat	1oz~32oz	PL10
Reheat	1oz~37oz	PL10
Veggies	1oz~48oz	PL10

Example, you want to cook 10 oz meat.

1. Place meat into the oven and close the door.
2. Press **Meat** pad once.
3. Press number pad enter weight.
4. Touch **Start/Add 30Sec** pad to start cooking.

### ➔ **Popcorn**

Popcorn lets you pop commercially packaged microwave popcorn. For example you want to cook a 3.5 oz bag of microwave popcorn.

1. Place the food into the oven and close the door.
2. Press **Popcorn** pad once, the display will show "2:05" and "START".
3. Press **Start/Add 30Sec** pad, the system start to cook immediately.

**NOTE:** Popcorn automatically sets the cooking time for a 3.5 oz. bag of microwave popcorn.

### ➔ **Beverage**

For example, you want to reheat two cups of coffee.

1. Place coffee into the oven and close the door.
2. Press **Beverage** pad once, the display will display "1".
3. Press number pad "2" to choose two cups.
4. Press **Start/Add 30Sec** pad to start cooking.

**NOTE:** For beverage, you can choose the amount by touching number pad 1 to 6, and the display will show number of servings instead of weight. Beverages heated with the beverage category may be very hot. Remove the container with care.

## **Kids Meals**

---

Using Kids Meals lets you heat common microwave-prepared foods without needing to program times and cook power.

For Hot dogs and Frozen sandwiches:

1. Press the **Kids Meals** pad once.
2. Press number pad "2 or 4" to choose Hot dogs or Frozen sandwiches.
3. Press **Start/Add 30Sec** to confirm your choose. The display will show "1" and "START".
4. Press **Start/Add 30Sec** pad to start cooking

For Chicken nuggets and Fresh fries:

1. Press the **Kids Meals** pad once.
2. Press number pad "1 or 3" to choose Chicken nuggets or Fresh fries.
3. Press **Start/Add 30Sec** to confirm your choice. The display will show "4" and "START".
4. Press number pad "1 or 2" to choose the food weight (1 for 4 oz, 2 for 8 oz).
5. Press **Start/Add 30Sec** pad to start cooking.

KIDS MEALS				
Category	Press number pad	Weight	Power level	Cooking time
Chicken nuggets	1	4 oz	PL-6	01:30
		8 oz		02:30
Hot dogs	2	1	PL-6	01:30
Fresh fries	3	4 oz	PL-6	01:30
		8 oz		02:30
Frozen Sandwiches	4	1	PL-8	01:20

## Weight Defrost

The oven allows you to defrost food based on the weight entered by user. The defrosting time and power level are automatically set once the food category and the weight are programmed. The frozen food weight ranges is 1~96 oz.

Suppose you want to defrost ground meat (15OZ.).

1. Touch **Weight Defrost** pad once.
2. Press number pad enter weight.
3. Touch **Start/Add 30Sec** pad to confirm.

### NOTE:

- During defrost, the oven will pause and sound beep to remind user to turn the food over, after that, press **Start/Add 30Sec** pad to resume.
- Use small smooth strips of aluminum foil to cover edges and thinner sections of the food.

## 1Lb Defrost

This feature allows you to defrost food quickly.

In standby, press **1Lb Defrost** pad once, the system start defrosting automatically.

### NOTE:

- During defrost, the oven will pause and sound beep to remind user to turn the food over, after that, press **Start/Add 30Sec** pad to resume.
- Use small smooth strips of aluminum foil to cover edges and thinner sections of the food.

## Time Defrost

If the food weight is exceed the maximum weight recommended, you need to use time defrost.

Suppose you want to defrost ground meat (12:34).

1. Touch **Time Defrost** pad once, "00:00"and"DEF."will display.
2. Enter defrosting time by touching the number pad **1、 2、 3、 4**.
3. Touch **Start/Add 30Sec** pad to confirm.

**NOTE:**

- During defrost, the oven will pause and sound beep to remind user to turn the food over, after that, press **Start/Add 30Sec** pad to resume.
- Please remember to place the food on a microwave-safe dish not in a plastic container

## OTHER CONVENIENT FEATURES

### Add 30Sec

---

In standby mode, simply touch the **Start/Add 30Sec** pad repeatedly to set cook time and the oven will start cooking immediately at 100% power level.

**NOTE:** You can also extend cooking time (except auto cook and 1Lb defrost) by touching the **Start/Add 30Sec** during cooking (each touch for 30 seconds up to 99 minutes and 99 seconds).

### Setting the Time

---

Suppose you want to time a 3 minutes cooking.

1. In standby mode or cooking process, touch **Timer** pad once, "00:00" and "TIMER" will display.
2. Use the number pads to enter time.
3. Touch **Start/Add 30Sec** pad.

**NOTE:**

- The longest time you can set is 99 minutes, 99 seconds.
- Once you have set the timer function, in either cooking or standby mode, you can check the countdown by press **Timer** pad and you can touch **Stop/Cancel** to cancel the timer function when the display shows timer time.

### Eco Mode

---

**To set:** In standby mode, press **Eco Mode** pad once to enter the power mode. At this point, the display is closed, press any key, return to standby status, the display will normal show, but the oven did not exit power mode. If there is not any operation within 1 minute, the system automatically enters the power saving mode.

**To cancel:** After set eco mode, in standby mode, presses **Eco Mode** pad once, the oven drop out power saving mode. At this moment, oven cannot enter power save mode if there are not any operations within 1 minute.

### Child Lock

---

The child lock prevents unsupervised operation by children and this program only works in standby mode

To set, in standby mode, press and hold **Stop/Cancel** for 3 seconds. LOCK is indicated on the display.

To cancel, press and hold **Stop/Cancel** for 3 seconds. LOCK indication disappears.

# CLEAR AND CARE

## Exterior

The outside surface is precoated steel and plastic. Clean the outside with mild soap and water; rinse and dry with a soft cloth. Do not use any type of household or abrasive cleaner.

## Door

Wipe the window on both sides with a damp cloth to remove any spills or spatters. Metal parts will be easier to maintain if wiped frequently with a damp cloth. Avoid the use of spray and other harsh cleaners as they may stain, streak or dull the door surface.

## Touch Control Panel

Care should be taken in cleaning the touch control panel. If the control panel becomes soiled, open the oven door before cleaning. Wipe the panel with a cloth dampened slightly with water only. Dry with a soft cloth. Do not scrub or use any sort of chemical cleaners. Close door and touch STOP/CANCEL.

## Interior

Cleaning is easy because little heat is generated to the interior surfaces; therefore, there is no baking and setting of spills or spattering. To clean the interior surfaces, wipe with a soft cloth and warm water. **DO NOT USE ABRASIVE OR HARSH CLEANERS OR SCOURING PADS.** For heavier soil, use baking soda or a mild soap; rinse thoroughly with hot water.

## Waveguide Cover

The waveguide cover is located on the ceiling in the oven cavity. It is made from mica so requires special care. Keep the waveguide cover clean to assure good oven performance. Carefully wipe with a damp cloth any food spatters from the surface of the cover immediately after they occur. Built-up splashes may overheat and cause smoke or possibly catch fire. **DO NOT REMOVE THE WAVEGUIDE COVER.**

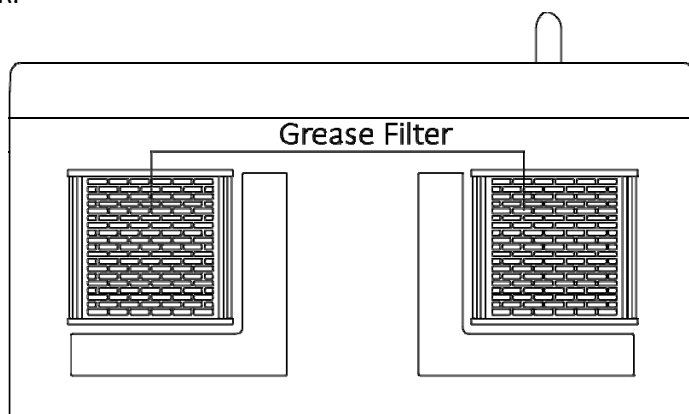

## Fan

The fan will automatically start when heat rises from range surface units or burners. This protects the microwave oven from excessive temperature rise. The fan will stay on until the temperature decrease. It cannot be turned off manually during this time.

For other uses, select either HI or LO speed.

## Odor Removal

Occasionally, a cooking odor may remain in the oven. To remove, combine 1 cup water, grated peel and juice of 1 lemon and several whole cloves in a 2-cup glass measuring cup. Boil for several minutes using 100% power. Allow to set in oven until cool. Wipe interior with a soft cloth.

## Turntable/Turntable Support

The turntable and turntable support can be removed for easy cleaning. Wash them in mild, sudsy water; for stubborn stains use a mild cleanser and non-abrasive scouring sponge as described above. They are also dishwasher-proof. Use upper rack of dishwasher. The turntable motor shaft is not sealed, so excess water or spills should be wiped up immediately.

## Grease Filters

Filters should be cleaned at least once a month. Never operate the fan or oven without the filters in place.

Pull down slightly on the tab toward the front of the oven and remove the filter. Repeat for the other filter.

Soak the filter in a sink or dish pan filled with hot water and detergent. DO NOT use ammonia or other alkali; they will react with the filter material and darken it.

Agitate and scrub with a brush to remove embedded dirt.

Rinse thoroughly and shake dry.

Replace by fitting the filter back into the opening.

## Light

To replace light bulbs, first disconnect power to the oven at the circuit breaker panel or by unplugging.

To release cover, remove the screw on the light cover. (See illustration.)

DO NOT USE A BULB LARGER THAN 30 WATTS.

Close light cover and secure with screw removed in step 2.

CAUTION: Light cover may become very hot. Do not touch glass when light is on.

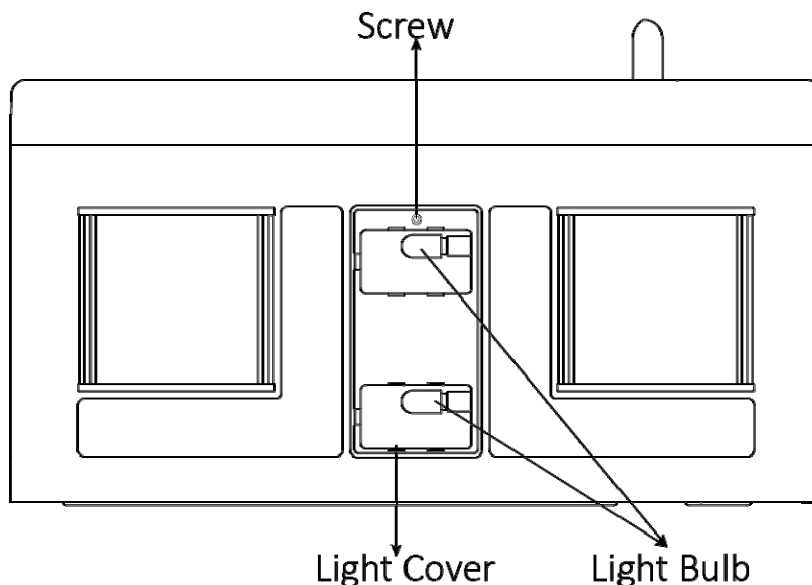

## Charcoal Filter

Charcoal filter is used for nonvented, recirculated installation. The filter should be changed every 6 to 12 months depending on use.

- Disconnect power to the oven at the circuit breaker panel or by unplugging.
- Remove the louver mounting screw from the top center of the louver and push down carefully on the tab at each end of the louver to disengage it. (See illustration.)
- Pull the louver away from the unit.
- Change the charcoal filter.
- Carefully push the louver back into place and replace the screw remove in step 2.

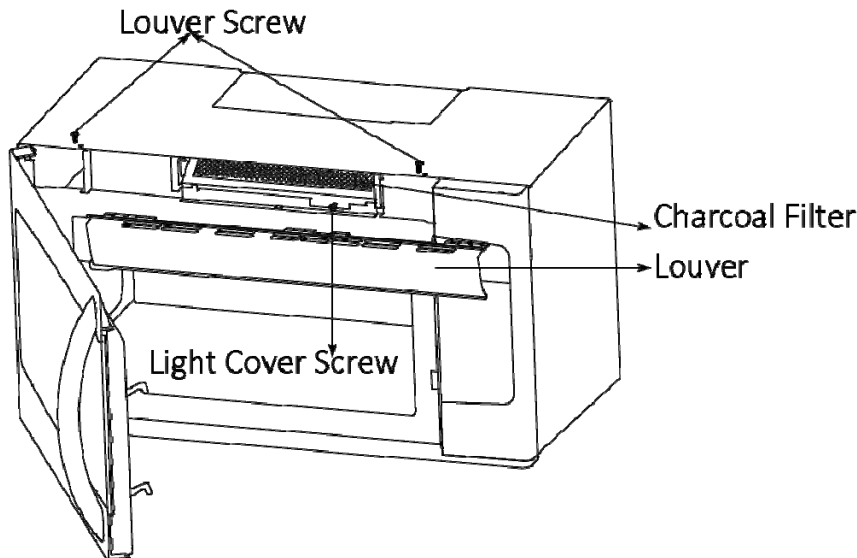

## Oven Light

Remove the louver per instructions 1~3 above and charcoal filter, if used.

- Open light cover located behind filter mounting by carefully pulling up on the front edge.

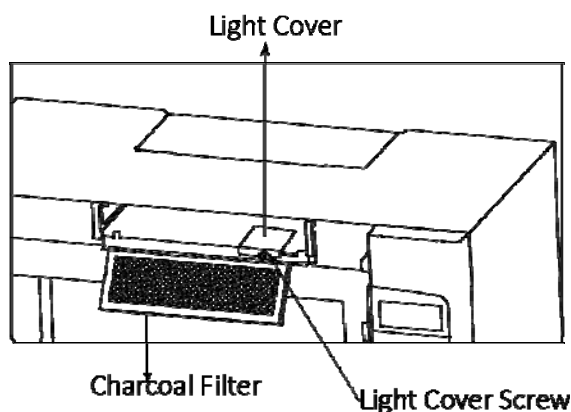

- DO NOT USE A BULB LARGER THAN 30 WATTS.
- Replace the oven light cover by carefully pushing into place. Replace the charcoal filter, if used. Push the louver back into place and replace the louver mounting screw.